



Some of the Complexities in the Special Theory of Relativity: New Paradoxes

Sergey Artekha^{1*}, Andrew Chubykalo² and Augusto Espinoza²

¹Space Research Institute of RAS, Moscow, Russia.

²Unidad Académica de Física, Universidad Autónoma de Zacatecas, Zacatecas, México.

Authors' contributions

This work was carried out in collaboration between all authors. All authors read and approved the final manuscript.

Article Information

DOI: 10.9734/PSIJ/2016/26788

Editor(s):

- (1) José Antonio de Freitas Pacheco, Laboratoire Lagrange, University of Nice Sophia Antipolis, France.
(2) Roberto Oscar Aquilano, School of Exact Science, National University of Rosario (UNR), Department of Science and Technology, Argentina.
(3) Abbas Mohammed, Blekinge Institute of Technology, Sweden.

Reviewers:

- (1) Anonymous, Kennesaw State, USA.
(2) A. Ayeshamariam, Khadir Mohideen College, Adirampattinam, Thanjavur District, India.
(3) Lung-Chien Chen, National Taipei University of Technology, Taiwan.
Complete Peer review History: <http://sciencedomain.org/review-history/15136>

Original Research Article

Received 1st May 2016
Accepted 16th June 2016
Published 24th June 2016

ABSTRACT

In this article we analyze some logical contradictions of the special relativity theory (SRT), concerning the time dilation and length contraction. The Lorentz transformations and the relativistic law for velocity addition are considered in detail. The notion of relativity and the transverse Doppler effect are discussed. The whole complex of numerous contradictions proves that the special theory of relativity is the Procrustean bed of physics.

Keywords: Time dilation; length contraction; logical contradictions; lorentz transformations; relativistic law for velocity addition; the notion of relativity; transverse doppler effect.

PACS: 03.30.+p; 04.20.-q

1. INTRODUCTION

Albert Einstein begins his famous paper [1] with the critic of non-symmetry of Maxwell's

equations. But these equations represent a generalization of experimental physical laws and observations. Later, Einstein rejected the Abraham force only on the grounds that it is not deduced from the general theoretical principles, though, gives a much better agreement with

*Corresponding author: E-mail: sergey.arteha@gmail.com;

experiments than a formula of the special relativity theory (SRT). Based on some of Einstein's memories, the opinion in [2] suggests that the creation of the SRT – is a purely theoretical breakthrough and has no need in the experimental studies at all. Can some mathematized theoretical principles be valued higher than experiments in the natural sciences? Obviously not!

The kind of asymmetry of mathematical arguments is well-known: An infinite number of confirming examples cannot outweigh even one counterexample (the logical contradiction). Logic, as part of the common sense, is more than any particular theory: All sciences are based on it. Therefore, a logically-inconsistent theory cannot be considered as scientific one. The SRT also cannot remain untouchable for the constructive logical analysis.

As a rule, the SRT uses mental experiments with two objects (the pairwise synchronization). But in this case there exists a unique mathematical relationship between classical concepts and relativistic ones (the recalculation is possible). This fact was perfectly understood by Henri Poincare. He considered new concepts and transformations as only one of the possible agreements on a par with the previous classical concepts (see in [3] the work *Final Thoughts*, chapter II and the commentary at the end of the book – the article of M.I. Panova, A.A. Tyapkin and A.S. Shibanova). However, new relativistic concepts give often mistakes when describing the spatial movement (not along one and the same line) and when the number of objects is greater than two.

Recently, multiple logical contradictions and physical inconsistencies inside the SRT increasingly attract the attention of professionals and are subjected to legitimate criticism (see [4-25], [30-32], Antirelativistic Library http://www.antidogma.ru/library/index_en.html). Figuratively speaking, the SRT by itself represents some impossible construction (as the well-known impossible cube). Each element of such a construction is non-contradictive by itself locally, but the complete construction shows a contradiction as a whole. Local mathematical errors are absent in the SRT, but as soon as we believe that the letter t means the real physical time, then we can immediately expand the construction, and contradictions will be detected. Just the same situation takes place with spatial characteristics.

The present paper discusses new paradoxes of the SRT and criticizes some aspects of this theory.

2. ON CONTRADICTIONS OF SRT

The theory of relativity stays in deep contradiction to the declared properties of the homogeneity and isotropy of space and physical meaning of used values. Let us start with a discussion of some paradoxes.

We traditionally begin with the paradox of twins [26-32]: to explain it, relativists involve the acceleration of one of the twins. The conventional explanation is that the physical situation is asymmetric and two reference systems are not equivalent (the symmetry is broken in the general relativity theory – GRT). We have no doubt that the manipulation with mathematical symbols (using the GRT or the lines of simultaneity in the SRT) can give the beforehand desired result for the SRT [27-29]. Magic of Mathematics bewitched some researchers. However, some *game with mathematical letters* is not enough for physics: physicists search for the causes of phenomena, mechanisms for their implementation and the physical meaning of the used values. This is just what physics is different from mathematics. Since our article has no relation to the general relativity theory at all, we consider some concrete pseudo-explanations of the twin paradox in the frame of the SRT only. We will not hide problems under the carpet, but we will try to highlight them in detail. We have no doubts that the proper time is independent on body movement or on any circumstances (in this property it looks like the usual classic time). Let the first brother remain in the inertial reference system without gravity, and the second brother is astronaut. Firstly, according to the SRT we shall remind ourselves that before acceleration, in opinion of each brother, the other one should appear younger. This statement is included in many relativistic textbooks (this is the initial position). During the flight (excluding the acceleration time), the situation is completely symmetrical with the twins in the SRT (this position accepted by all relativistic textbooks). Therefore, in opinion of each brother, an increase of the age of the other one should occur less than his own age change for such a flight. As it is known from all relativistic textbooks, the brother-astronaut was accelerated and exactly he was found to be younger than the brother-homebody at the meeting (it is the final position). Since the rejuvenation is impossible

(including the proper time), so the twin-astronaut cannot become younger, but the twin-homebody became much older. Since the only influence was acceleration, then, **from the viewpoint of the twin-astronaut**, he is accelerated, but the other brother grows older. Where is the cause of the phenomenon presented here? And there is no mechanism in the SRT (acceleration of the first brother cannot influence on the senescence of the second brother)! Secondly, we can see from Fig. 1 that the path length $|OA|$ and $|BC|$ with acceleration can be chosen to be the same one (fixed). But for different experiments, we can change the path length $|AB|$ of flight with some constant large speed. As an example, the distance of 50 light years can be chosen in the first case and the distance of 100 light years - in the second case. It is obvious that one and the same acceleration cannot explain differences in the age of the corresponding twins (50 or 100 years respectively) for these different cases. Otherwise the causality is lost: the acceleration is just one and the same, but its influence is different for these different pairs of twins! Thirdly, the brother-homebody can take part in the accelerated movements at sections $|OA|$ and $|AK|$ only (there and back). These sections are fully identical to the analogous sections for the brother-astronaut (there: $|OA|$ and $|BC|$; back: $|CB|$ and $|AO|$). The twin-homebody can start at the calculated moment when the twin-astronaut will fly through point R. Only the displacement of starting time of accelerated motions is observed. Therefore, the differences in the accelerations disappear, since these two brothers were involved in the identical (according to their own time) accelerated movements.

Fourthly, we suppose now the other situation. The first brother remains on the Earth (with the usual gravity). He is influenced by g during all the time of the experiment. The second brother accelerates with the same usual g only at sections $|OA|$, $|BC|$, $|CB|$ and $|AO|$. Note that relativistic speeds can be achieved with the acceleration g for a time of about a year. Consequently, the astronaut is affected by g only a small part of his flight. According to the GRT, the influence of gravitation with g and the influence of acceleration g are equivalent. Who will now be younger? The mechanism of the influence of the acceleration (for the one brother) on the age of the second twin is absent in all considered cases. Thus, the coincidence of mathematical symbols is dovetailing, and the initial explanation of the twin's paradox by means of acceleration (Einstein, Pauli, Born, Laue) do

not have any scientific value and can be handed over in a "dusty archive".

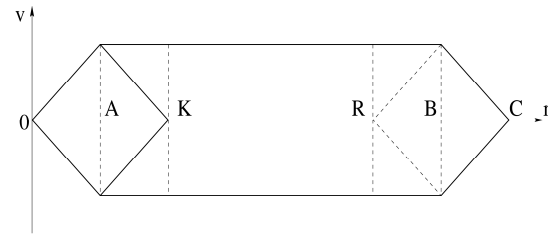

Fig. 1. The role of accelerations in the paradox of twins

We would remind ourselves the following. Any results obtained by one observer in classical physics can be applied by any other observer (including scientists not participating in the given experiment) in his own investigations. In such a case, our purpose is to offer some symmetrical construction, for which results are evident from the common sense. But relativists must consider different results from the viewpoint of different observers and compare all results between themselves. Let two human colonies A and B be at some big distance from each other (Fig. 2). Some beacon O is placed at the middle of this distance $|AB|$. The beacon sends a signal, and when the light sphere simultaneously reaches both colonies, each launches a spaceship with families of astronauts. To reach large equal speeds, the laws of acceleration (for both spaceships) are chosen equal in advance.

Since a change of time course is declared in the SRT, but not a transfer of initial time (as the time zone on the Earth, for example), we will formulate a paradox of coevals – people born in the same year. Let two babies were born on each spacecraft just after accelerations became equal to zero. The quiescent observers at the points A_1 and B_1 can confirm the fact of the births of the babies. These children are chosen for a comparison of age within experiment. All previous history of accelerated motion (up to the points A_1 and B_1 respectively) does not exist for them. The babies differ in that they moved relative to each other at a certain constant speed within their entire lives. They travelled equal distances $|OA_1| = |OB_1|$ up to the meeting at the beacon. For example, let the flight of child 1 with some constant speed take place for a time of 17 years. From the SRT viewpoint, the first child can reason in the following manner. The second child moved relative to me with a big velocity all my life (17 years). Therefore, his age must be less than

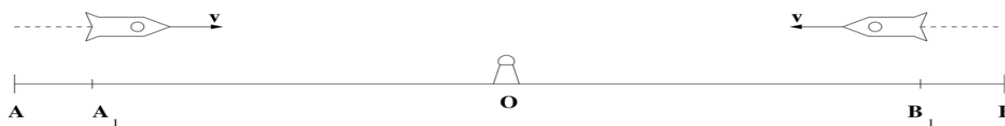

Fig. 2. The paradox of coevals

mine own. Besides, if he counts out the age of the second child starting from the moment of the receipt of the confirmation from B_1 , then he will believe that he will see an infant with his feeding bottle at the meeting. But the second child can reason about the first child in the same manner. However, the true result is obvious from the full symmetry of the motions: the age of both astronauts are the same. This fact can also be confirmed by the quiescent observer at the beacon. Besides, the astronauts can photograph themselves at this instant (without stopping) and write their age on the back side of the picture, or even they can exchange pictures by a digital method. It is nonsense, if wrinkles appear on the face in the picture of one of the children during the deceleration of the other child. Moreover, it is unknown beforehand if one of the astronauts will wish to move with acceleration in order to turn around and catch up with the other child.

Imagine that two identical spaceships fly along two identical circular orbits, one nearby the other (or even in the bound state) around a star. Obviously, according to the SRT (and to the GRT) time flows equally on both systems fixed relative to each other's spaceship. Consider now the second situation (Fig. 3) – we split the spaceships and turn one of the orbits around an arbitrary diameter on 180 degrees. Now spaceships move along the same orbits, with the same speed but rotate around the star in opposite directions, meeting twice during one revolution (at the points A and B).

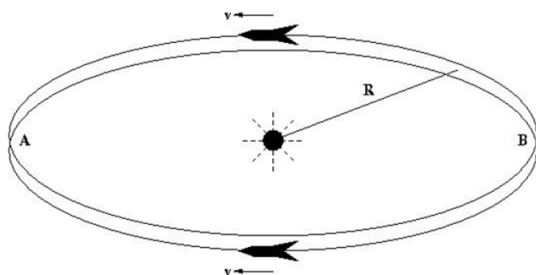

Fig. 3. Rotations in the opposite directions

It is obvious that the influence of the GRT effects on the course of time for both spaceships

remained unchanged. But there is the contradiction with the effect of SRT – now spaceships move relative to each other with a non-zero speed all the time (recall that the relativistic formula includes the square of the speed). Regardless how many nanoseconds were here – rejuvenating apples would be painted here! Since the number of revolutions can be arbitrary, it remains only to decide this, to whom of them award the Grand Prize: to being younger? To whom moves clockwise or counterclockwise? And from which side it is necessary to see – from above or below? Actually, it is obvious that the problem is completely symmetrical, and *no difference in time can exist*. This means that the contribution from the SRT effects (relativistic time dilation) is completely absent! The centrifugal acceleration (non-inertiality) prevents relativism? No problem! Let the linear velocity of the spaceships be close to the speed of light. We will increase the radius of the orbit R so that the c^2/R tends to zero (for example, there were many orders of magnitude smaller than the existing accuracy of its measurement). Then no experiments detect the non-inertiality. The ratio of centrifugal acceleration to the centrifugal acceleration on the Earth can be made less than any arbitrarily small value ϵ by choosing large radius R . For example, you can take $\epsilon \sim 10^{-10}$ or $\epsilon \sim 10^{-100}$. But all SRT experiments performed on the Earth with $\forall \epsilon \sim 1!$ There is no sense to fight for the need of strict inertiality; otherwise there would be no subject of study itself for SRT at all.

We can construct a symmetrical scheme of flower-type (Fig. 4), which includes rectilinear sections, where a large speed remains constant (inertial systems). The movement of each spaceship consists of 5 segments.

Starting from one point with unified acceleration (for example, g) along identical loops (accelerating segments 1), spaceships pass again the same single point. Therefore, the time spent by each spaceship (i or j) on this speeding-up will be the same both from the viewpoint of a quiescent observer and from the viewpoint of any astronaut: $t_{1i} = t_{1j}$. Further, the

spaceships move uniformly and rectilinearly (inertial path sections 2). After that identical rotary loops (segments 3) follow. For the rotary loops, it is also easy to prove that $t_{3i} = t_{3j}$ (any loop can be obtained from another one with the help of some parallel translation and some turn). Further, the spaceships again move uniformly and rectilinearly (inertial sections 4 coincide with inertial sections 2, but in reverse order). Finally, movements are completed in brake loops (path sections 5 coincide with path sections 1). Deceleration is performed in the reverse order to the starting acceleration: $t_{5i} = t_{5j} = t_{1i} = t_{1j}$. The scheme is completely symmetrical, so the total time of the motion for all the astronauts is one and the same: $t_i = t_j$. Everything said above reflects the properties of isotropy and homogeneity of space. Since the motion of each spaceship consists of motions along these five path sections, we finally have for the rectilinear path sections (inertial sections): $t_{2i} + t_{4i} = t_{2j} + t_{4j}$ for any i and j . However velocity has vector nature and the relative velocity depends on i and j . And the SRT formula includes the square of the relative velocity only. Hence, according to the SRT the course of time must be different, and that leads to contradictions both between the astronauts and with the data of the stationary observer. Thus, *the presence of some non-zero relative velocity cannot be the cause for the effect of the time dilation.*

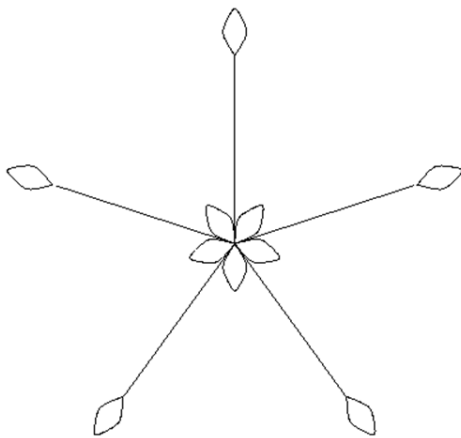

Fig. 4. Flying over the symmetrical scheme of flower-type

Note some strange thing concerning reversibility. Passing from one inertial system of reference to the other and back, we see that the linear Lorentz transformations are completely equivalent both for the coordinates and for the time, namely, they are reversible. Then it seems

rather strange that the difference between lengths of bodies vanishes with the return to the initial place in the SRT (for example, in the paradox of twins), but the disparity remains in the time elapsed.

A methodically correct aspect of classical physics is the comparison of the running of an arbitrary process with a standard one, i.e. with process completely independent of it. This allows you to compare different processes with each other for a unified objective description of reality. The relativistic method represents a step backward in comparison with the classical one (it is like measuring the time by our own heartbeats, or using the pigeon post – the Einstein synchronization method). The infinitely remote source of periodic signals, which is situated perpendicular to the direction of the body motion (the relative motion of bodies or systems), can serve as a watch counting the universal absolute time (which remains one and the same regardless of choice of the inertial system of reference).

Since all SRT conclusions can be obtained from the invariance of an interval, then using the above-proved equality $dt = dt'$ and the relativistic equality $c = constan$, we obtain $dr = dr'$. Nevertheless, we irrespectively consider some disputable points in relativistic spatial concepts.

Imagine that three spaceships with astronauts flew in the direction to the coordinate origin. One spaceship moved uniformly along the X -axis for 100 years with a speed $0.99c$, the second spaceship moved uniformly along the Y -axis for 1000 years with a speed $0.9999c$ and the third spaceship moved uniformly along the Z -axis for 1 million years with a speed $0.999999c$. And these three spaceships simultaneously pass the origin of coordinate. All the astronauts look at the surrounding Universe and make an exchange by telegrams. Astronauts from the first spaceship argue that the whole Universe is reduced along the X -axis by 10 times, while astronauts from the second spaceship believe that the Universe only shrank along the Y -axis by 100 times, while astronauts from the third spaceship are convinced that the same Universe shrank by 1000 times along the Z -axis. Who has gone crazy? The movement of a spaceship compresses the entire universe. It is without any physical mechanism. Reincarnation of Baron Munchausen! Or the entire universe is not compressed, but only a part (respectively of 100, of 1000 and of 1000000 light years), not to

violate the causality principle? And there appears a gap with the rest of the Universe? Any of the choices is obvious relativistic nonsense.

Pay attention to another strangeness (the paradox of distances). The shortening of lengths of objects is associated with properties of space itself. Therefore, regardless of whether we approach the object or move away from it, the distance to objects must also be shortened. Then, if the speed of a spacecraft is high enough ($v \rightarrow c$), we can touch distant stars (and not only look at them), because our own dimensions do not change in our own system of reference. Besides, the value of acceleration is not limited by the SRT. Therefore, when flying away from the Earth for a long time, we will eventually be at the distance of just *one meter* from it. In which moment of time will the observer (at this distance in one meter) see the reverse motion of this spacecraft (contrary to the action of rocket engines)? Now we consider the paradox of pedestrians, which is associated with the relativistic effect of contraction of distances. The following mental experiment will be agreed in advance (Fig. 5).

At the middle of a segment is placed a beacon, which sends a signal toward its ends. Let the length of the segment be 1000000 light years. At the time of arrival of the flash: two pedestrians from the ends of the segment begin to go with some equal speed towards a single preselected side, along the straight line containing the given segment, and they will walk for several seconds. The moving segment (a system of two pedestrians) should be shortened relative to the motionless segment by some hundreds of kilometers. However, none of the pedestrians will fly away for hundreds of kilometers during these seconds. Since the Lorentz transformation laws are continuous, the moving segment cannot likewise be torn off at the middle. In such a case, where has this segment been shortened? And how can this be detected?

Let us recollect the Galilee proof by the method of division of the whole into parts: there are no reasons to increase twice the acceleration of free falling body with the increasing twice of the mass of this body. Let us consider now the paradox of a cut-in-half ruler. Four identical rulers are shown in Fig. 6.



Fig. 5. The paradox of two pedestrians

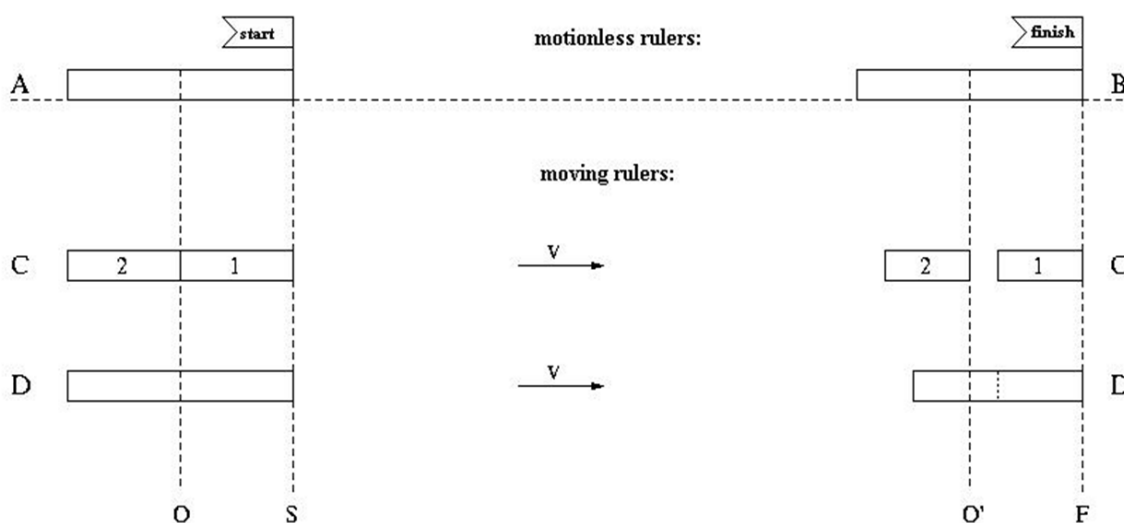

Fig. 6. The paradox of a cut-in-half ruler

The quiescent ruler A lies on start and the quiescent ruler B lies on finish as the standards (for clarity only). Being cut on two equal parts (1 and 2), the ruler C will move during the experiment. But the same ruler D will move as the whole during the experiment. At first, the movement of the first half of ruler $C - 1$ will be considered separately. The ruler $C - 1$ starts to move with uniform acceleration, reaches some large speed V , flies with such a constant speed and crosses the finish line F by its right end. Suppose now that the second half of the ruler $C - 2$ started to move simultaneously with the first half $C - 1$ and moved under the same law (as the first half $C - 1$). Then, its right end will cross the line O' at the time of crossing of the finish by the first half of a ruler $C - 1$. We obtain the obvious result: the situation with the second half of the ruler $C - 2$ differs from the situation with the first half of the ruler $C - 1$ only by parallel translation of the beginning of coordinates. Therefore, the right end of a half of a ruler is parallel translated from the line S to the line O . But for the uncut ruler D the situation on the finish will be quite different (the ruler reached the finish as the whole one). We have a logic contradiction. First, whence can ruler C know about its cutting? Secondly, the cut of the zero value cannot turn to a nonzero spatial gap according to the SRT. Besides, a ruler can be cut in arbitrary number of parts, and it is impossible to rescue all cuts from the gap.

Now we consider the following spatial paradox. Suppose that a thin rod of some length L fly along the X -axis with a speed v . Let the plate with a niche of the same size L runs with a speed V in a direction of the Z -axis. The rod will precisely pass through the niche in the classical case. Contradictions in indications of different observers are ostensibly eliminated by the introduction of the relativistic turn of the rod. But the relativistic angle of the rod turning uniquely depends on the ratio of speeds. Therefore, this situation can elementarily be re-made in a dramatic one. To do this, let the other smaller rod l slide with a speed on our first rod. Observers on both rods can claim about the absence of the clearance between the rods. However, in accordance with the SRT, the large rod L and the small rod l will be turned at different angles relative to the plate for the observer on the plate (because of a different speed of rods v and v_1). Therefore, the small rod will be turned upwards relatively to the large rod, and there appears a

clearance between these rods. There is the obvious contradiction.

To make this contradiction even more vivid, we use the principle of division of a whole into pieces. At first, we consider rod l as a single whole. Then (see Fig. 7), the second half of rod l is raised at some height above rod L , on which a sliding occurs. After that, we consider the other situation with the small rod consisting of two real halves. In this case, the given situation for the second half-rod is fully similar to the case of translation of origin. Therefore, these halves appear with the forward ends on the large rod, but spatially divided (see Fig. 7). Such a situation is especially strange: the cut of the zero size must remain zero size at any turns or multiplications on the relativistic factor in the SRT. Let us notice that we slightly helped the SRT, rotating the small half-rods above the larger one. The cause of the contradiction: no real firm bodies exist in the SRT at all, impenetrable one to the other, since all SRT formulas are derived for light flashes. But light flashes can pass through each other. Consequently, to reconcile evidences of arbitrary observers (for example, at the rod center), it is necessary to assume as if one rod passes through another (absurd discrepancy of the model to reality).

Now we pass to the consideration of the relativistic law for velocity addition. If two systems participate in relative motion, the determination of their relative velocity causes no doubts (neither in the SRT nor in classical physics). Let now a system S_2 be moving relative to a system S_1 at some speed v_{12} . Further, let a system S_3 be moving relative to S_1 in the same direction at speed v_{13} . In substance, the relativistic law for velocity addition defines the relative velocity of that movement in which the observer does not participate. Namely, the speed of motion of system S_3 relative to S_2 is determined as

$$v_{23} = \frac{v_{13} - v_{12}}{1 - v_{13}v_{12}/c^2} \quad (1)$$

Usually, v_{13} is expressed in terms of v_{12} and v_{23} . But equation (1) has precisely that form, which discloses the real essence of this law: it tells what relative velocity of systems S_3 and S_2 will be recorded by the observer in S_1 , if the Einstein light-signal method is applied for time synchronization and for measuring length. In fact, we have some *law of visibility*.

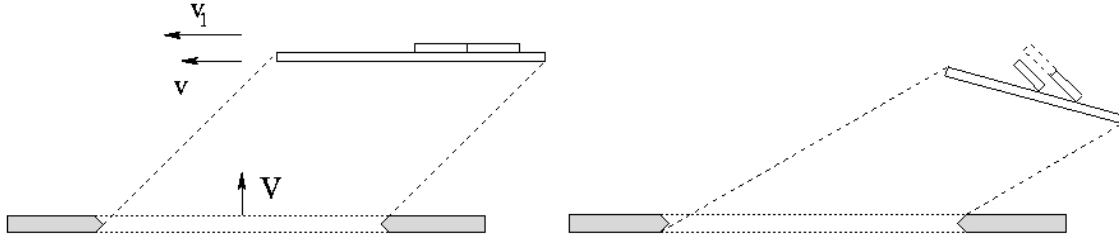

Fig. 7. The relativistic paradox of the turn of sliding rods

The following methodological remark can be made. There is one very strange fact from the SRT: the non-commutativity of the relativistic law for velocity addition of non-collinear vectors (usually, only the relativistic law for velocity addition for rectilinear motion is discussed in textbooks). This property of non-commutativity and the fact, that the Lorentz transformations without rotations do not compose a group, are mentioned only briefly in some theoretical physics textbooks. In contrast, a similar property in quantum mechanics fundamentally changes the entire mathematical formalism: it physically expresses a simultaneous immeasurability of non-commuting values. What essentially be changed in this case? Obviously nothing!

As it can be seen from the general relativistic law for velocity addition:

$$v_3 = \frac{(v_1 v_2) v_1 / v_1^2 + v_1 + \sqrt{1 - v_1^2 / c^2} (v_2 - (v_1 v_2) v_1 / v_1^2)}{1 + (v_1 v_2) / c^2} \quad (2)$$

It is clear that the result depends on the order of transformation. As an example, we consider two cases, where vectors \mathbf{i}, \mathbf{j} indicate the unit vectors of the Cartesian coordinate system. In the first case of sequence $+v_1 \mathbf{i}, -v_1 \mathbf{i}, +v_2 \mathbf{j}, -v_2 \mathbf{j}$, we obtain the zero total velocity. But for the other order of the same quantities $+v_1 \mathbf{i}, +v_2 \mathbf{j}, -v_1 \mathbf{i}, v_2 \mathbf{j}, -v_2 \mathbf{j}$ we obtain the non-zero total velocity. It depends on v_1 and v_2 in a rather complicated manner. So, the successive application of transformations of $v_1 \mathbf{i}$ and $v_2 \mathbf{j}$ gives

$$v_3 = v_1 \mathbf{i} + \sqrt{1 - v_1^2 / c^2} v_2 \mathbf{j}.$$

But in the other order of $v_2 \mathbf{j}$ and $v_1 \mathbf{i}$ it gives the other result:

$$v'_3 = v_2 \mathbf{j} + \sqrt{1 - v_2^2 / c^2} v_1 \mathbf{i}.$$

That is, for these two cases we have the completely different vectors (Fig. 8). In such a case, what can the decomposition of some concrete velocity vector into components imply?

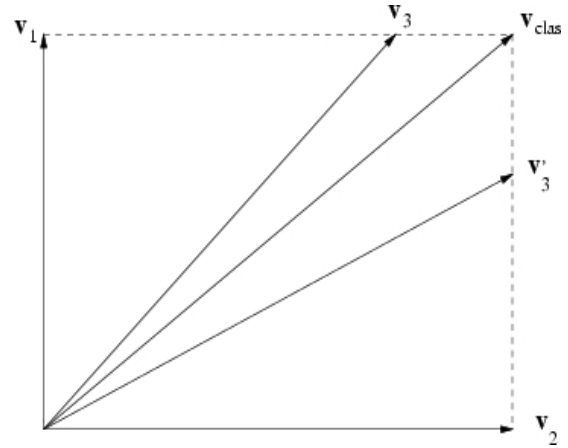

Fig. 8. Velocity parallelograms in SRT

We consider the following questions. Can the Lorentz transformation laws describe successive transitions from one inertial system to another one? Can the relativistic law of velocity addition describe real velocity changes? We believe not! At first, let us recall the goal of the relativistic law of velocity addition. It must justify the existence of an universal speed limit and prove that the addition of any motions seemingly cannot lead to a speed greater than the speed of light. Give an example. The Earth moves relative to stars - it is the first reference system. Let a spaceship fly up from the Earth with high velocity. Factually, it is created the second reference system. Further, the next spaceship flies up from the first spaceship - it is created the third system of reference, etc. This represents the meaning for consecutive transformations, since for non-commutative transformations it is important, which of the velocities is the first velocity, which is considered as the second one, etc. Now we consider the Lorentz transformation law for arbitrary directions of motion:

$$\mathbf{r}_1 = \mathbf{r} + \frac{1}{V^2} \left(\frac{1}{\sqrt{1 - V^2/c^2}} - 1 \right) (\mathbf{rV})\mathbf{V} + \frac{\mathbf{V}t}{\sqrt{1 - V^2/c^2}}, \quad (3)$$

$$t_1 = \frac{t + (\mathbf{rV})/c^2}{\sqrt{1 - V^2/c^2}}. \quad (4)$$

It can be easily checked, that the successive application of the relativistic law of velocity addition (2) to velocities

$$v_1\mathbf{i}, \quad v_2\mathbf{j}, \quad -v_1\mathbf{i} - \sqrt{1 - v_1^2/c^2} v_2\mathbf{j} \quad (5)$$

gives zero. Applying the Lorentz transformation laws successively with the same set of velocities to an arbitrary vector $\mathbf{r} = x\mathbf{i} + y\mathbf{j}$, we obtain:

$$\mathbf{r}_1 = \frac{x + v_1 t}{\sqrt{1 - v_1^2/c^2}} \mathbf{i} + y\mathbf{j}, \quad (6)$$

$$t_1 = \frac{t + xv_1/c^2}{\sqrt{1 - v_1^2/c^2}} \quad (7)$$

Further, we find:

$$\mathbf{r}_2 = \frac{x + v_1 t}{\sqrt{1 - v_1^2/c^2}} \mathbf{i} + \frac{y\sqrt{1 - v_1^2/c^2} + v_2 t + xv_1 v_2/c^2}{\sqrt{1 - v_1^2/c^2} \sqrt{1 - v_2^2/c^2}} \mathbf{j}, \quad (8)$$

$$t_2 = \frac{t + xv_1/c^2 + yv_2 \sqrt{1 - v_1^2/c^2}/c^2}{\sqrt{1 - v_1^2/c^2} \sqrt{1 - v_2^2/c^2}}. \quad (9)$$

Due to some awkwardness of the expressions for \mathbf{r}_3 and dt_3 , we will not write down them in the explicit form. But with the help of graphic programs, we can be sure in the following properties:

- 1) The initial time is desynchronized at any point of space in the new system, except the coordinate origin.
- 2) The time intervals is changed: $t_3 \neq dt$; that is, we found ourselves in some new moving system, rather than in the initial quiescent system.
- 3) Line segments became not only of changed length, but also are rotated at some angle. We can easily be convinced of this if we find numerically the angle of rotation:

$$\alpha = \arctan \left(\frac{y_3[x(1), y(1), t] - y_3[x(0), y(0), t]}{x_3[x(1), y(1), t] - x_3[x(0), y(0), t]} \right) - \arctan \left(\frac{y(1) - y(0)}{x(1) - x(0)} \right). \quad (10)$$

From the physical viewpoint, the situation is quite simple. Such properties indicate the non-objective (i.e. only illusory) character of the Lorentz transformation laws and of the relativistic law for velocity addition, and show their disagreement with each other. Indeed, we have successively passed from one inertial system to another one, but the rotation implies the non-inertial character of a system. Therefore, the SRT itself escapes the limits of its own applicability; i.e., it is inconsistent. If this rotation were real, it would mean that the notion of inertial system has a non-objective character (since the result would depend on the method of transition to the given system). As a consequence, there is the lack of a proper basis for the existence of the SRT itself.

The transformation of forces in the SRT looks methodically completely unclear at transition from the one frame of reference to another. Let us consider, for example, two identical in absolute value charges $+e$ and $-e$ being at distance r from each other (Fig. 9).

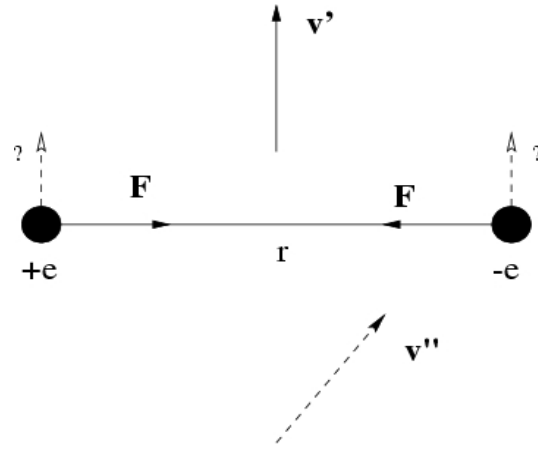

Fig. 9. Parallel flying charges

In the frame of reference bound with resting charges there exists the electric force $F = e^2/r^2$ acting between the charges. Look now at the same charges from the system moving at velocity \mathbf{v}' perpendicular to the line connecting the charges (in this system the charges are flying parallel to each other). According to the SRT, now the force acts between the charges:

$F' = G e^2 / r^2$, where $G = \sqrt{1 - v^2/c^2}$. To what physical quantity should the transformation factor G be related? The charge is invariant in the SRT. Distance r , which is perpendicular to the motion, does not it change either. So, do the forces really lose their physical causes in the SRT? Note the next strange thing: if the velocity of an observer \mathbf{v} has a component along the line which connects the charges, the force acting on the charges has a component which is perpendicular to this line (i.e. the picture of motion is essentially changed). Generally speaking, the idea itself that the one and the same force can be different for different systems of reference is nonsense for all experimental physics. It is obvious that the way of writing Arabic ciphers on a dynamometer is independent on observer motion, i.e. readings of the dynamometer (fixing the force) will not be changed with observer motions. Any force acts between the source of this force and the concrete object of the applied force. Therefore, the motion of some "strange eyes" has no relation at all (i.e. the force can depend on the source properties, object properties, and their mutual motion).

Of course, a finite time for propagation and transmission of interactions results in a change of the observed motion of particles. An additional dependence of quantities on velocity appears; for example, for an effective mass (more precisely for the effective force). This can be understood qualitatively from the following elementary mechanical model. Consider just one-dimensional motion; let a source emit continuously and uniformly similar particles flying at a constant speed v_1 along the straight line. At any place of the straight line, a test body placed to rest will be subject to action of a constant pressure force (from bombarding particles). If now a test body moves away from the source at some velocity v , then the number of particles reaching this body per time unit will decrease. This can be interpreted as a decrease of the effective force (or seeming increase of the effective mass). Being accelerated under the effect of particles in the limit $v \rightarrow v_1$, the seeming effective mass of the body tends to infinity (more correctly to say, the effective force tends to zero).

One can easily show that the relativistic equation of movement with a force \mathbf{F} can be simply written down as the classical second law of Newton with some other force \mathbf{F}' . At first, we explicitly find a derivative on the left-hand side of the relativistic equation $\frac{d\mathbf{p}}{dt} = \mathbf{F}$. Then we multiply the left

and right parts of this equation on \mathbf{v} in scalar way. As a result, the auxiliary expression follows

$$\frac{m(\dot{\mathbf{v}}\mathbf{v})}{(1 - v^2/c^2)^{3/2}} = (\mathbf{F}\mathbf{v}). \quad (10)$$

Substituting the expression (10) in the initial relativistic equation, it turns out the second law of Newton with the new force \mathbf{F}' (see the expression at the right-hand side):

$$m\dot{\mathbf{v}} = \sqrt{1 - v^2/c^2} (\mathbf{F} - \mathbf{v}(\mathbf{F}\mathbf{v})/c^2). \quad (11)$$

There are many examples from mechanics and hydrodynamics with the fully non-relativistic area of speeds, when forces appear depending on the speed of body movement (and the concept of the attached mass can be entered). If this is so, is there something great in the similar relativistic dependences of force on velocity? Of course no! It would seem, instead of a letter \mathbf{F} one can use any force in the given expression of force \mathbf{F}' . But there exist no proofs that the relativistic equation of movement can be applied to something, except to the charged particles being under an action of the Lorentz force. We remind that the Lorentz force was not the unique form for an electromagnetic force during the different time periods. Among the well-known previous expressions there were: Ampere's force, Weber's force, etc. Fields are manifested on their power influence. Therefore, if the modern electrodynamics had the self-consistent character, then the expression for electromagnetic force should be directly deduced from the Maxwell equations, instead of being artificially entered. Such an expression has been received in [17], but its form differs from the expression of the Lorentz force. Incidentally, the experiments that were interpreted as proofs of the reality of relativistic length contraction and time dilation have a simple alternative interpretation [33] in terms of velocity-dependent forces present in the systems.

Contrary to an artificially maintained opinion, the limiting transition from relativistic mechanics to classical mechanics does not exist (for some values there is not even an approximate transition!). Thus, the limiting transition from the Lorentz transformations to the Galileo transformations for the time ($t = t' + vx'/c^2$) shows that the Newtonian mechanics is not simply a limit of low speed $v/c \ll 1$, but what is required is a quite different condition $c \rightarrow \infty$, but the finite speed of light was defined in classical physics in the 17th century!

Let us list only some oddities of the SRT, which in principle cannot be coupled with classical physics (regardless of the speed of movement). Newtonian space possesses an important property: systems with lower dimensions can possess similar properties. For example, the vector can be introduced not only in space but also on the line and the plane. At the SRT spatial values do not possess vector properties (only 4-vector), i.e. there is no continuous limiting transition to classical quantities ("nearly vector" → vector). 4-speed is always orthogonal to the 4-acceleration. 4-speed of light is infinite. Here it may also be mentioned the non-commutativity of the relativistic velocity addition law for non-collinear vectors (fundamental difference).

The limiting transition to the classical energy is also inconsistent. We mentioned earlier about the condition of such a transition $c \rightarrow \infty$. But then, not only the energy of rest, but also any energy becomes $E = \infty$. The limiting transition to low velocities for many variables raises a number of questions. All formulas should pass to the Newtonian form, when the rate of transmission of interactions is supposed infinite (e.g., Lagrange function, action, energy, the Hamiltonian function, and others.). However, we see that it is not so: 4-velocity goes over in a set of four numbers (1,0,0,0) and does not mean anything, the 4-acceleration – also; the interval $S \rightarrow \infty$; the components of 4-power tend to zero set, etc. This clearly shows that all these relativistic quantities and expressions cannot have an independent physical meaning.

Detailed coverage of the history with the transverse Doppler effect and the calculation of the value of effect are given in [16]. Here we present another method for derivation of the classic result. The following forgery claim is made for the Doppler effect in the SRT: it is considered the dot light flashes (i.e. **spherical waves!**), but results are compared with the classical Doppler effect for **plane-parallel waves**. It is clear that no transverse Doppler effect exists for plane-parallel waves. And if someone does not understand the difference between spherical and plane waves, then, apparently, he doesn't understand neither mathematics, nor physics (for instance, the following problem can be solved and an exact solution can strictly be found at the level of middle school: how many wave peaks per unit of time will be detected by an observer moving along a line over the water surface, if some oscillating up and down float excites circular waves?).

At first, we study spherical waves excited by a moving dot source in the environment (for example, circles on water or a sound waves can be considered). Let a quiescent receiver of signals be placed at the point R. If a source was fixed at the point O, the direction of the signal distribution would be represented by a line RO. In this case, we can divide the distance |OR| on the number of accomplished oscillations in the time of passage of the given distance and obtain the length of a wave. An analogous situation would be for a source which is placed at some other point j. Let now some source move rectilinearly with a constant speed v. For the calculations, we can arbitrarily choose some segment of signal with length equals to the wavelength and study such a signal by observing a point that correspond to the beginning of this signal (it is quite equivalent for uniform movement: we can watch the motion of the middle or of the end of this conditional allocated signal). The source passed the point O at the moment of the beginning of the signal emission. The source passed the point j at the moment of the beginning of the reception of the same signal by the receiver (see Fig. 10). Usually, an angle θ is introduced in the theory of the Doppler effect - it is the angle between velocity and the supervision line, measured in the receiver system. We can easy define the change of a period of perceived oscillations T' in comparison with the period T of oscillations for the source based at a point O. It can be found from interrelation of the sides of a triangle (wavelengths), if the length of each side is divided into number N of the oscillations made during this time, where $T = t/N$, $T' = t'/N$. To do this, we can use the theorem of cosines:

$$(ct)^2 = (vt)^2 + (ct')^2 - 2(ct)(vt) \cos(\pi - \theta).$$

Solving this quadratic equation for t' , we found $t' = t(\sqrt{1 - \beta^2 \sin^2 \theta} - \beta \cos \theta)$, where as usually $\beta = v/c$. As a result, we obtain the following expression for the shift of frequency:

$$\nu' = \frac{\nu}{\sqrt{1 - \beta^2 \sin^2 \theta} - \beta \cos \theta}. \quad (12)$$

Now we consider the second case: a quiescent source j excites spherical waves in the medium, but the receiver moves rectilinearly with a constant speed v. It passes the point R at the moment of the beginning of the signal reception. The situation to this moment is shown in Fig. 11. By analogy, we can use the theorem of cosines

for the given triangle $(ct)^2 = (vt)^2 + (ct)^2 - 2(ct)(vt)\cos(\pi - \theta)$. We can resolve the quadratic equation for t' and obtain: $t' = t(\sqrt{1 - \beta^2\sin^2\theta} - \beta\cos\theta)/(1 - \beta^2)$. As a result, the formula of the Doppler effect for spherical waves is found:

$$v' = v(\sqrt{1 - \beta^2\sin^2\theta} - \beta\cos\theta). \quad (13)$$

Correctness of this expression at any distances follows from the procedure of derivation of the formula. In fact, the angle θ varies in the course of movement (unlike the case of plane-parallel waves), but it automatically tracks distance between the receiver and the source. First of all, notice the following peculiarity of the formula obtained. There exists the transverse Doppler effect for spherical waves in classical physics (if to substitute $\theta = \pi/2$ in the last equation (13)), fully coinciding with the relativistic expression. As a result, we have the expression of the Doppler effect for spherical waves at simultaneous movement of the source and the receiver:

$$v' = \frac{v(\sqrt{1 - \beta_1^2\sin^2\theta_1} - \beta_1\cos\theta_1)}{\sqrt{1 - \beta_2^2\sin^2\theta_2} - \beta_2\cos\theta_2}. \quad (14)$$

Max Laue was the last relativist who wrote down unified expression simultaneously including both movement of a receiver and a source. After that, probably, relativists have understood the contradiction of the simultaneous account of both movements to the relativistic ideology itself. However, the question remains: which of the two formulas to eliminate (after all, A. Einstein applied both)? As a result, different authors use different expressions in the work. In addition it is not clear, how one and the same relativistic expression for the Doppler effect can simultaneously lead to two classical formulas of the Doppler effect at limiting transition? But both of them are experimentally proved and lead the different observed results (for example, for sound).

3. DISCUSSION AND CONCLUSION

Consideration of the work of electromagnetic clocks indicates that the time dilation is not a kinematic effect [34].

Despite the fact that the relativistic law for velocity addition can be derived from the Lorentz transformations, there is disagreement between

them. Let us try to clarify this issue. To do this, we recall the appropriate derivation in the one-dimensional case. We consider a mutual movement of systems K and K' . Starting from the Lorentz transformation laws

$$x_1 = \frac{x + Vt}{\sqrt{1 - V^2/c^2}}, \quad t_1 = \frac{t + xV/c^2}{\sqrt{1 - V^2/c^2}},$$

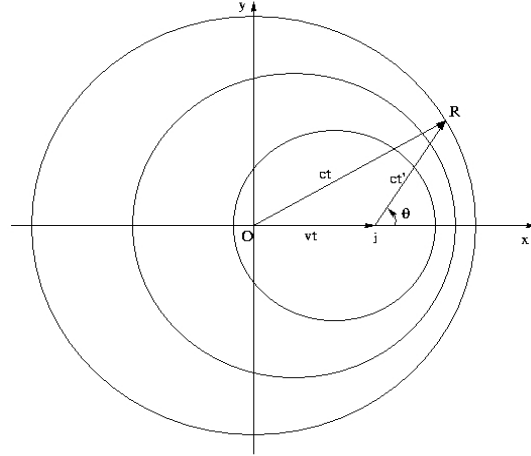

Fig. 10. The Doppler effect with a moving source

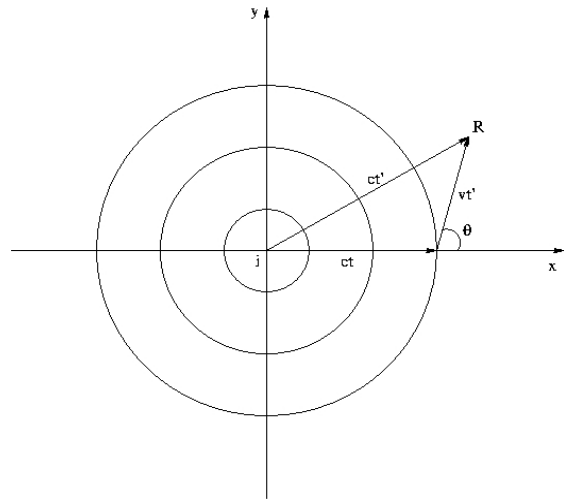

Fig. 11. The Doppler effect with a moving receiver

We divide the differential dx_1 by dt_1 with regard to definitions $v = dx/dt$ and $v_1 = dx_1/dt_1$ and find the well-known expression:

$$v_1 = \frac{v + V}{1 + Vv/c^2}.$$

Because of the method of obtaining the formula as such, we see the following.

- 1) The observer is located at the origin of the reference system K and measures the distance x to the studied object in his own system K .
- 2) The observer supposes time t to be universal in his own reference system and determines the velocity of the object in his system according to the formula $v = dx/dt$.
- 3) Using his own (!) time t , the observer defines speed $-V$ of system K' with respect to K and supposes the relative velocities of systems to be mutually opposite in direction. This observer cannot measure any other value. Therefore, the summary velocity v_1 is a computable quantity.

Thus, the usage of some particular rules of the SRT led to some apparent effect (not real). Formally, any arbitrary number of velocity values can be sequentially substituted into the formula for the relativistic law. However, from the very meaning of the formula, we cannot simply pass even to the second substitution for determining v_2 . In the case of addition of movements along one and the same straight line, the classical property of commutativity is maintained, and the contradiction is veiled. Some another approach can be applied, if we will search for such a sequence of three transformations of velocities that retains the initial time in the Lorentz transformation laws invariant. Then, it can easily be checked that, instead of (5), a unique sequence must be used:

$$v_1 \mathbf{i}, \quad v_2 \mathbf{j}, \quad -v_1 \mathbf{i} \sqrt{1 - v_1^2/c^2} - v_2 \mathbf{j}.$$

But first and most importantly, the turning of segments remains. Second, a new set of velocities of the given succession does not satisfy the law of velocity addition. Factually, the order of substitution of the velocities v_1 and v_2 is changed (but this is inconsistent with the essence of the studied law). Therefore, the contradictions are not eliminated in this case too.

The phrase (widely distributed by relativists) looks absolutely strange: as if the SRT is simply some new geometry and, therefore, is allegedly non-contradictory. But physics and mathematics - are completely different sciences. Physics studies real causes of phenomena and concrete

mechanisms directly influencing on the phenomenon under investigation. Certainly, obtaining mathematical solutions of physical equations, different transformations of coordinates are frequently applied (conformal ones, for example). Actually, these are elementary substitutions only. However, if somebody claims that the real transformation of the whole Universe from the outer region into the inner one of a circle follows from correctness of some solutions, then all physicists would know "the adequate place" for such a claim. So, the Lorentz transformations do not guarantee the objective character of kinematic effects at all. Firstly, these transformations are not the unique mathematical invariants of the wave equation. As an example, the Fought transformations have been discovered formerly. They represent the invariant of the wave equation also. Secondly, no physical principles follow from mathematics itself: the invariance property is fully determined by a combination of mathematical operations and symbols in the expression. For instance, the Lorentz-type transformations with the replacement of speed of sound instead of the speed of light c can be applied for some acoustic problems just due to invariance. Thirdly, the Lorentz transformations are derived for the process of propagation of light flashes in absolute emptiness. But this is a completely particular idealized phenomenon, and one should not be exaggerated its universality. Let us notice that if some mathematical equation is invariant as relative to the Lorentz-type transformations with some constant c , it indicates the following. Among special solutions of the given equation there are surfaces of the wave type, capable to extend with such speed c . Besides, other quite different solutions with their own invariant transformations can exist even in the given equation, not to mention the other mathematical equations. So, from the mathematical viewpoint, no global mathematical generalizations follow from the fact of invariance at all. It looks funny a relativistic attempt *to inflate a soap bubble from the particular phenomenon* and *to clone* some invariance on the properties of the Universe. Although all atoms consist of electrons and protons, nobody makes global conclusions from the invariants of the heat conductivity equation for H_2 or from features of hydrogen plasma only on this fact. Look at crystals, at the live beings, at Space! Everyone can see: the whole Universe demonstrates that its symmetries do not coincide with the primitive spherical symmetry of dot light flashes in vacuum. With using one scalar

constant c , one cannot obtain even speed of light in real gases, liquids, crystals; not to mention that, in the general case, perturbations in the medium are propagated with the other speed - speed of a sound. This speed cannot be determined by one constant also, because it depends on concrete properties of the propagation medium (it is anisotropic in crystals, for example). In the general case, it is obvious that no possibility exists to adjust all features of the Universe to one scheme of invariance. Besides features of vacuum, atoms and molecules possess a huge variety of properties. Elements of environment are involved in processes of light distribution. Additionally, interaction with devices is involved also. All above mentioned individualizes the processes at once. Therefore, there must be at least something average between properties of emptiness and properties of concrete substance. Thus, any special transformations cannot impose restrictions on all physics.

In general, actions of the SRT in kinematics can be called *obtaining images using flashes of light*. It is known that images can be enlarged, reduced, distorted and false (in a curved mirror). But in any branch of physics, besides the SRT, on the basis of such images the conclusion about the change of properties of the objects themselves is not made. On the contrary, a way to calibrate to extract the real information was searched. All high-profile space-time effects of the SRT are fiction.

Obvious examples of the incompleteness of only relative values are present in classical mechanics; therefore the SRT (with its absolutization of relativity) cannot be a more general theory in principle. Contrary to the key idea of the isolation of systems for the application of the concept of *relativity* to them, relativists use the exchange of signals between the systems. In addition to the classic examples of differences between open and closed systems (in the hold or on the deck of a ship), there are differences to the process of establishing solutions. For example, the start of motion of a frame in the magnetic field causes an instantaneous emergence of a current in it, but the movement of a magnet leads to the emergence of current some time later. Further, the presence of any dynamic characteristics (in addition to the kinematic ones) immediately individualizes the process. Consider an elementary example: Let some small ball drop to the Earth non-elastically. Define kinetic energy, which was transformed

into heat. Relative velocity is *one and the same* for the ball and for Earth. Why do we substitute into the formula, the mass of the ball but not the mass of the planet Earth? These examples demonstrate that only locally absolute velocities play a role (using the relative velocity, one can sometimes get an approximate answer).

The status of the SRT is the following. It is some method for re-calculation of the picture of pure electromagnetic phenomena from the one inertial reference system into the other inertial reference system under the condition that all processes of interactions are established ($t > \tau = L/c$).

Final conclusion: we believe that the return to classical concepts of space, time and all derivative values is required. These notions are based on all set of experimental data and have the greatest degree of generality in comparison of any particular theory or system of equations.

COMPETING INTERESTS

Authors have declared that no competing interests exist.

REFERENCES

1. Einstein A. Zur Elektrodynamik bewegter Körper. Ann. Phys. 1905;17:891-921.
2. Frankfurt UI, Frank AM, Optika Dvizhushchikhsya Tel (Optics of Moving Bodies, Moscow: Nauka); 1972.
3. Poincare A. On Science, (Nauka, Moscow); 1983.
4. Dingle H, Science at the Crossroads, (Martin Brian & O'Keeffe, London); 1972.
5. The Einstein Myth and the IVES Papers, (Edited by Dean Turner and Richard Hazelett, Devin-Adair Pub. / Hope Publishing House, 1977, 2005).
6. Essen L. The special theory of relativity - a critical analysis. Oxford University Press; 1971.
7. Marinov S, The Velocity of Light is Direction Dependent. Czech. J. Phys., B 24, 1974;965-970.
8. Marinov S. Measurement of the laboratory's absolute velocity. General Relativity and Gravitation. 1980;12(1):57-66.
9. Zapffe CA, Seven short essays on $(1 - v^2/c^2)^{-1/2}$: An epistemological analysis of the Lorentz transformation and the chronometric branch of relativistic physics. Lakeland Color Press, Brainerd; 1977.

10. Scheunemann E, Irrte Einstein? Skeptische Gedanken zur Relativitätstheorie – (fast immer) allgemeinverständlich formuliert, (BoD - Hamburg-Norderstedt); 2008.
11. Sutliff D. Why physics cannot assume the relativity of motion or an infinite universe: Problems with special and general relativity. *Physics Essays*. 1991;4:217-222.
12. Whitney CK. The twins, the mesons, and the paradox. *Apeiron*. 1997;4:104-109.
13. Whitney CK. Finding absolution for special relativity theory. *Galilean Electrodynamics*. 1996;7:23-29.
14. Tolchelnikova-Murri SA. The doppler observations of venus contradict the SRT. *Galilean Electrodynamics*. 1993;4:3-6.
15. Tolchelnikova-Murri SA, Some conclusions from the studies of stellar aberration, "Galileo back to Italy", *Atti del Convergnio Internazionale*, Bologna, "Andromeda". 1999;395-404.
16. Akimov OE. *Natural sciences*. Unity Dana, Moscow; 2001.
17. Smulsky JJ. *The theory of interaction*. Publishing House "Cultural Information Bank", Ekaterinburg; 2004.
18. Munera HA. Michelson-morley experiments revisited: Systematic errors, consistency among different experiments, and compatibility with absolute space. *Apeiron*. 1998;5:37-53.
19. Arteha SN. On the basis for special relativity theory. *Galilean Electrodynamics*, 14. Special Issues. 2003;2:23-28.
20. Arteha SN. Some remarks to relativistic kinematics. *Spacetime and Substance*. 4, N 3/18, 2003;114-122.
21. Artekha SN, Criticism of the foundations of the relativity theory, (Editorial URSS, Moscow, 2004; LKI, Moscow; 2007). [In Russian; see English translations. Available: <http://www.antidogma.ru>
22. Arteha SN, Critical remarks to the relativity theory. *Spacetime and Substance*. 6, N 1/26, 2005;14-20.
23. Arteha SN. Critics of some aspects of the special relativity theory, *International Scientific Conference "Space, Time, Gravitation"*, Proceedings, TESSA, Saint-Petersburg. 2007;7-17. [In Russian]
24. Wankow B, *Wissenschaftstheorie und Relativitätstheorie - Eine kritische Untersuchung der philosophischen Grundlagen der Relativitätstheorie*, Tabvla Rasa. *Jenenser Zeitschrift für kritisches Denken*, Ausgabe. 2011;43.
25. Leus VA, Triplet paradox in special relativity and discrepancy with electromagnetism. *Engineering Physics*, No 1, 2016;11-22.
26. Langevin P, L'evolution de l'espace et du temps. *Scientia*. 1911;10:31-54.
27. Laue Das M. Relativitätsprinzip. *Wissenschaft*. 1913;38.
28. Einstein A, Dialog about objections against the theory of relativity. *Die Naturwissenschaften*. 1918;48:697-702.
29. Wheeler J, Taylor E, *Spacetime Physics*, (W. H. Freeman: New York); 1992.
30. Dray T, The twin paradox revisited. *Amer. J. of Phys*. 1990;58:822-825.
31. Cranor MB, Heider EM, Price RH. A circular twin paradox. *Amer. J. of Phys*. 2000;68:1016-1020.
32. Grandou T, Rubin JL. On the Ingredients of the Twin Paradox. *Int.J. of Theor. Phys*, 48, N.1, 2009;101-114.
33. Jefimenko OD, On the Experimental proofs of relativistic length contraction and time dilation. *Zeitschrift Für Naturforschung*, 53a, 1998;977-982.
34. Jefimenko OD. Direct calculation of time dilation. *American Journal of Physics*. 1996;64(6):812-814.

© 2016 Artekha et al.; This is an Open Access article distributed under the terms of the Creative Commons Attribution License (<http://creativecommons.org/licenses/by/4.0>), which permits unrestricted use, distribution, and reproduction in any medium, provided the original work is properly cited.

Peer-review history:
The peer review history for this paper can be accessed here:
<http://sciencedomain.org/review-history/15136>